

Ball Valve Type C 100

New
Also in PVC-C



Size:

- DN 10 up to DN 50

Design:

- Not only the body but also completely assembled in full operation the valve withstands the nominal pressure rates in relation to the operating temperature

Material with high durability

- All material with high impact resistance

Range of application:

ASV ball valves are not only used for shut-off but can also be applied for control purposes.

Type of fluids:

Neutral, aggressive or gaseous liquids provided that the selected materials are resistant at operating temperature. Refer to the ASV resistance guide.

Examinations:

Requirements and examinations to DIN 3230, 3441, 3442, 8063, 16 962. Leak rate 1.

Materials:

Housing:	uPVC, PVC-C, PP or PVDF
Ball:	uPVC, PVC-C, PP or PVDF
Ball seat:	PTFE
Seals:	EPDM or FPM

Nominal pressure¹⁾:

uPVC	PN 16
PVC-C	PN 16
PP	PN 10
PVDF	PN 16

Media temperature:

Depends on the operating conditions (system pressure, load etc.). Taking creep strength into account, the following approximate temperatures apply:

uPVC:	- 10 up to + 60 °C
PVC-C:	0 up to + 80 °C
PP:	+10 up to + 80 °C
PVDF:	- 30 up to +140 °C
EPDM:	- 30 up to +140 °C
FPM:	- 30 up to +140 °C
PTFE:	- 30 up to +140 °C

Operating pressure:

See material dependent pressure/temperature diagram.

Actuation:

- Manual with T-handle, also as position indicator.
- With pneumatic or electric drives or variable speed drives, connection acc. to DIN/ISO 5211.

Connection:

- Union socket with
 - Inserts (PVC) with solvent welding acc. to DIN 8063.

- Inserts made of PP and PVDF with flange socket ends for fusion welding acc. to DIN 16 962.
- Inserts made of PE on request.
- Inserts according to BS, ANSI, JIS on request.
- Flange connection acc. to DIN 2501 (PN 10/16) according to ASV face-to-face dimensions.
- Flange connection acc. DIN 2501 (PN 10/16) with DIN face-to-face dimensions on request.

Installation:

Variable independent of flow direction.

Colour:

Housing:

- uPVC: grey, RAL 7011
- PVC-C: grey, RAL 7001
- PP: grey, RAL 7032
- PVDF: opaque, yellowish-white
- T-handle: orange, RAL 2004

Option:

- Wall and actuator mounting sets.
- Also with position indicator and control devices according to DIN ISO 5211.

¹⁾ for H₂O, 20 °C

Operating pressure:

See material pressure/temperature diagram.

The pressure/temperature limits are applicable for a computed operating life factor of 25 years at PN 10.

The values are a guide for harmless fluids (DIN 2403) the material of the valve is resistant against.

For other media see the ASV resistance guide.

Durability of wear and tear parts is depending on the working conditions of the application.

Values < 0 °C (PP < +10 °C) on request with exact data of operation.

Pressure/temperature diagram

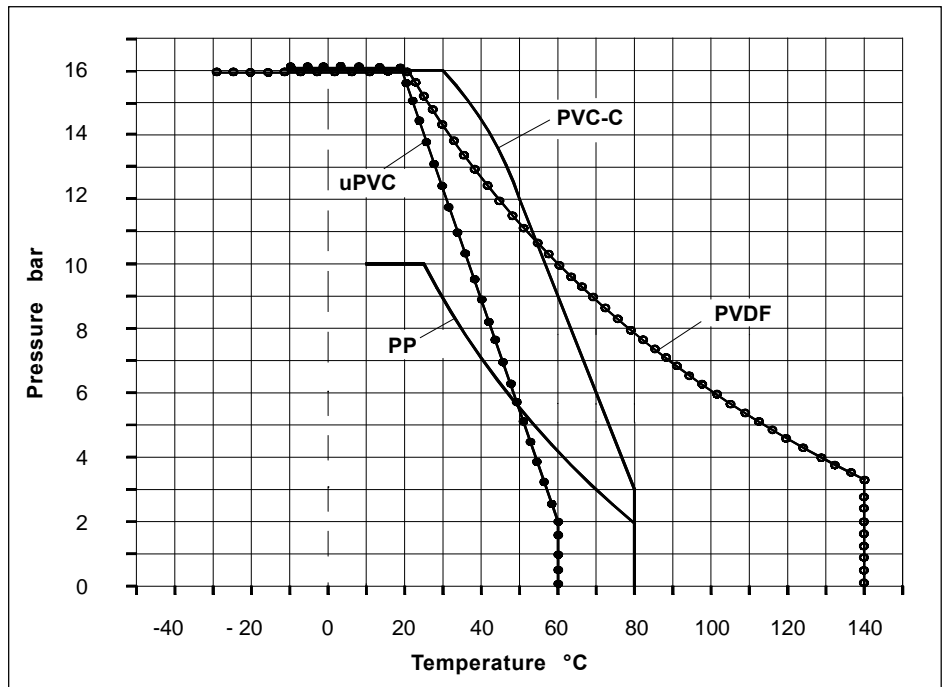

Pressure loss and k_v -values:

The chart shows pressure loss Δp in relation to flow Q.

For calculation:

$$k_v = 14,28 \times C_v = 17,09 \times f_v$$

Pressure loss curve C 100 (standard value for H₂O, 20 °C)

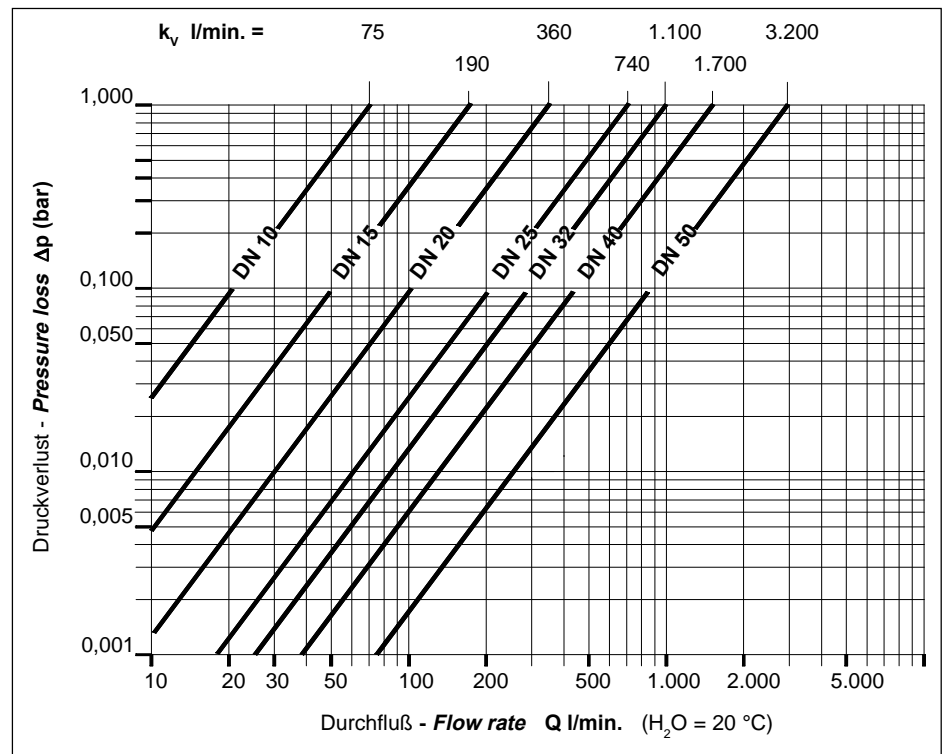

Torque:

The stated torques are approximate values.

They have been determined as follows: Pressure $p = 16$ bar for PVC/PVDF and $p = 10$ bar for PP with H₂O.

Depending on the fluid the value can be higher or lower.

Torque Nm

Size	DN 10	DN 15	DN 20	DN 25	DN 32	DN 40	DN 50
PVC	2,5	2,5	3,6	4,5	6,2	8,5	11,0
PP	2,0	2,0	3,0	4,0	5,8	8,0	10,3
PVDF	2,5	2,5	3,6	4,5	6,2	8,5	11,0

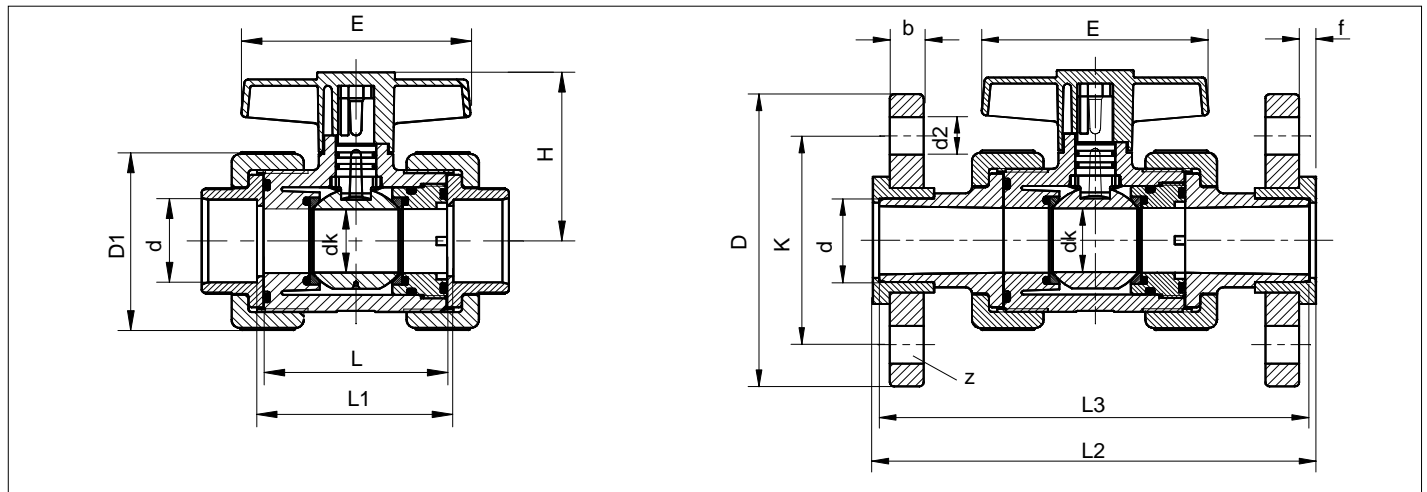
Dimensions C 100

Size			Dimensions mm															
d	DN	DN	b	dk	D	D1	d2	E	f	H	K	L1			L	L2 ²⁾	L3 ³⁾	z
mm	mm	Inch										PVC	PP	PVDF				
16	10	3/8	12	13,5	90	49	14	78	6	51	60	65	71	70	59	150	144	4
20	15	1/2	12	13,5	95	49	14	78	6	51	65	65	68	67	59	150	144	4
25	20	3/4	14	18,0	105	59	14	88	7	61	75	78	84	83	72	170	164	4
32	25	1	15	23,5	115	69	14	98	7	70	85	82	90	89	76	180	174	4
40	32	1 1/4	17	30,5	140	86	18	108	8	81	100	92	103	102	86	210	204	4
50	40	1 1/2	17	38,5	150	101	18	118	8	90	110	99	114	112	93	230	224	4
63	50	2	18	49,0	165	123	18	144	9	110	125	119	140	138	113	278	272	4

Ident-No. (socket ends)

Housing: Connection:			uPVC socket ends ⁴⁾		PVC-C socket ends ⁴⁾		PP socket ends ⁵⁾		PVDF socket ends ⁵⁾		Weight (kg) (standard value)		
Sealing element			EPDM	FPM	EPDM	FPM	EPDM	FPM	EPDM	FPM	PVC	PP	PVDF
d	DN	Inch	ID-No.	ID-No.	ID-No.	ID-No.	ID-No.	ID-No.	ID-No.	ID-No.			
16	10	3/8	118627	118655	124050	124058	118635	118663	118643	118671	0,16	0,13	0,21
20	15	1/2	118628	118656	124051	124059	118636	118664	118644	118672	0,16	0,13	0,21
25	20	3/4	118629	118657	124052	124060	118637	118665	118645	118673	0,27	0,20	0,35
32	25	1	118630	118658	124053	124061	118638	118666	118646	118674	0,38	0,29	0,50
40	32	1 1/4	118631	118659	124054	124062	118639	118667	118647	118675	0,68	0,47	0,89
50	40	1 1/2	118632	118660	124055	124063	118640	118668	118648	118676	0,98	0,74	1,27
63	50	2	118633	118661	124056	124064	118641	118669	118649	118677	1,68	1,17	2,19

Ident-No. (flange)

Housing: Connection:			uPVC GFR flange		PVC-C GFR flange		PP GFR flange		PVDF PP/steel flange		Weight (kg) (standard value)		
Sealing element			EPDM	FPM	EPDM	FPM	EPDM	FPM	EPDM	FPM	PVC	PP	PVDF
d	DN	Inch	ID-No.	ID-No.	ID-No.	ID-No.	ID-No.	ID-No.	ID-No.	ID-No.			
16	10	3/8	122210	122218	124162	124169	122226	122234	122242	122250	0,36	0,33	0,41
20	15	1/2	122211	122219	124163	124170	122227	122235	122243	122251	0,41	0,38	0,46
25	20	3/4	122212	122220	124164	124171	122228	122236	122244	122252	0,62	0,55	0,70
32	25	1	122213	122221	124165	124172	122229	122237	122245	122253	0,83	0,74	0,95
40	32	1 1/4	122214	122222	124166	124173	122230	122238	122246	122254	1,43	1,22	1,64
50	40	1 1/2	122215	122223	124167	124174	122231	122239	122247	122255	1,88	1,64	2,17
63	50	2	122216	122224	124168	124175	122232	122240	122248	122256	2,88	2,37	3,39

²⁾ Face-to-face dimensions acc. to ASV works standards for an easier mounting of the valve with flange connection. DIN face-to-face dimensions on request. ³⁾ Face-to-face dimensions for spigot ends for fusion welding ⁴⁾ for solvent welding ⁵⁾ for fusion welding

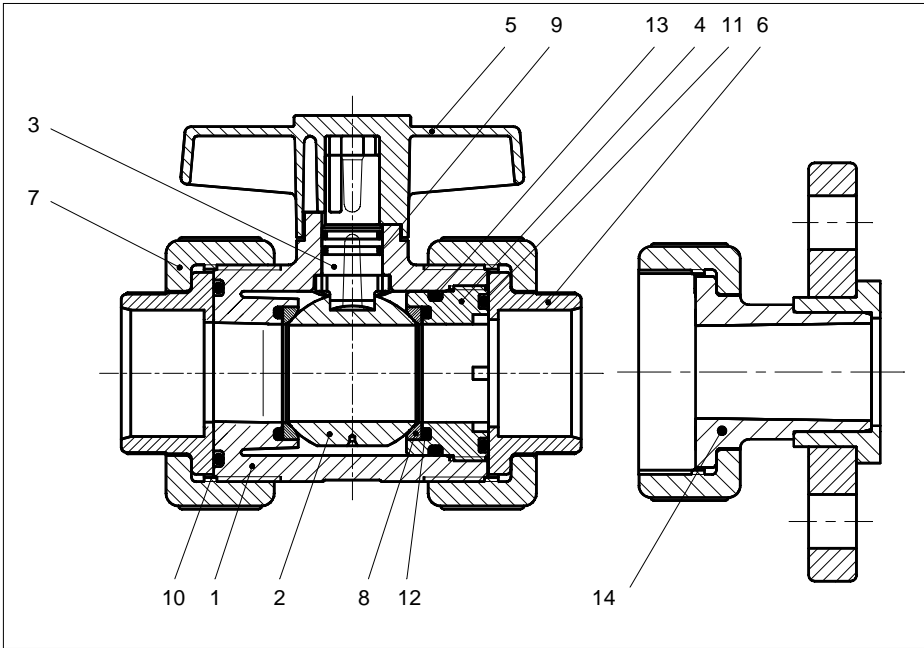

Pos.	Description	Qty.
1	Housing	1
2	Ball	1
3	Shaft	1
4	Threaded end bush	1
5	T-handle	1
6	Insert	2
7	Union nut	2
8	Ball seat	2
9	O-ring	2
10	O-ring	1
11	O-ring	1
12	O-ring	2
13	O-ring	1
14	Flange-spigot	2

Operating instructions:



Safe operation of the valve can only be ensured if it is properly installed, operated, serviced or repaired

by qualified personnel according to its intended use while observing the accident prevention regulations, safety regulations, standards and technical regulations.

The intended use includes adhering to the specified limit values for pressure and temperature as well as the chemical resistance referring to the operating conditions.

For this purpose, ensure that all components getting in contact with the media are »resistant« in accordance with the ASV resistance guide.

The owner/user must inform the authorized qualified personnel instructed to perform the assembly, inspection and/or maintenance work of any potential danger emanating from the machine line/medium, and ensure that suitable safety measures are observed including local regulations and laws of the territories of use.

In addition, always observe the operating and maintenance instructions of other component manufacturers.

Non-observance of the specified information and safety instructions may lead to injuries and/or property damage.

Installation:

- The respective space has to be selected on the pipeline and to be cut for installation.

The sockets together with the nuts have in case of PVC to be cemented, in case of PP/PVDF to be welded onto the pipe.

The valve body is to be mounted between the two nuts which have to be fastened hand tight.

Note In case of flange connections acc. to DIN length the nut of fixing the screws must be flat.

- The torque for the nuts should be in respect to thermoplastic flanges.
- After proper installation the pipe system with all components has to be tested for leakages.

1. Disassembly:

Note Dismounting and dismantling should always be carried out in accordance with workers protection rules and with accident prevention regulations.

- The pipe section is to be shut off and to be emptied.
- Any fluid rest is to be disposed properly.
- Remove the union nuts (7) from the valve and take the valve radially out of the pipeline.
- Turn ball (2) into closed position. Push out the ball. Pull off the T-

handle (5) from the shaft (3).

- Turn out the threaded end bush (4) with the lugs of the T-handle.

Attention Do not damage the ball.

- Push or pull the shaft (3) out of the housing (1).
- Ball seat (8) to be taken from the threaded end bush (4) and the housing (1).
- O-rings (9, 10, 11, 12 and 13) can be removed.

Note As spares use only original ASV parts.

2. Assembly:

- Assemble the valve in the reverse order.
- Install the valve by radially mounting it with the union nuts into the pipeline.
- After proper installation the pipe system with all components has to be tested for leakages.

Note Elastomeres, especially the EPDM sealing elements, should not be touched or cleaned with synthetic oils, mineral oils, fats or cleaning agents. Danger of swelling. Only appropriate fats should be used, e.g. silicone greases.

Technical alterations excepted