

**Pressure Relief
Valve
Overflow Valve
Type DHV 715
Type DHV 716
Type DHV 725**

High repeating accuracy,
with union sockets or
spigot ends



The optimal monitoring valves

- Sizes DN 10 up to DN 50
- Operating pressure up to 10 bar (PN 10)
- Wide set range:
DHV 715: 0.2 - 4.0 bar
DHV 716: 0.5 - 10.0 bar
DHV 725: 0.2 - 10.0 bar
- Low pressure increase up to fully opened valve
- Low hysteresis of only approx. 0.3 bar
- Opening pressure difference:
DHV 715 appr. 0.2 bar
DHV 716 appr. 0.4 bar
DHV 725 appr. 0.2 bar

Great operating security and long service life

- steady low vibration controlling
- hermetically sealed by diaphragm with crimped O-rings
- low maintenance
- easiest installation acc. ASV modular design system
- variable installation independent of flow direction
- pressure settings at any time, also during operation

High-quality materials

- PVC-U, PP or PVDF body, natural PP on request
- PTFE-coated diaphragm on fluid side
- safe mounting with stainless steel bolts

Easy connection to the pipeline

- threaded necks acc. DIN 8063 completed with union nuts, O-ring sealings and inserts
- radial demountability even after mounting
- spigot ends for solvent or fusion welding acc. ISO/DIN

Constructional features

- High reproducibility.
- Short face-to-face dimension.
- Injection moulded threaded necks acc. to DIN 8063.
- Direct mounting on any valve support by metal inserts in the body. The movability of the union nuts is not effected.

Range of application

Directly controlled by the operating fluid the DHV is used in all technical processes where a constant working and system pressure is required on the primary side and for avoiding any undesired pressure increase.

The DHV can also be used as overflow valve. For this purpose the DHV is to be mounted at the place where a T-piece is installed in the pipeline.

Valve functions and design

Normally the valve is closed and the piston respectively the valve seat is only admitted to the secondary pressure. Any rise of working or inlet pressure (primary side) above the pre-set pressure value activates the diaphragm and lifts the piston against the spring force. The valve opens and the pressure drops down in the secondary pipeline.

The moulded diaphragm constructed for full opening of the valve separates the fluid in the lower body from the bonnet respectively the atmosphere. The sealed tightness especially at higher temperature is secured by crimped seal O-rings at the diaphragm.

Valve setting and adjustment

The presetting or readjustment is made by removing the protection cap at setting control screw with a counternut and by reading the set pressure from the ASV diaphragm pressure gauge guard type 901 in the pipe system. The counternut can be leaded.

Pressure relief valve with pressure gauge

For neutral fluids the valve can be equipped with a gauge, normally at the primary side.

Sectional drawing DHV 725

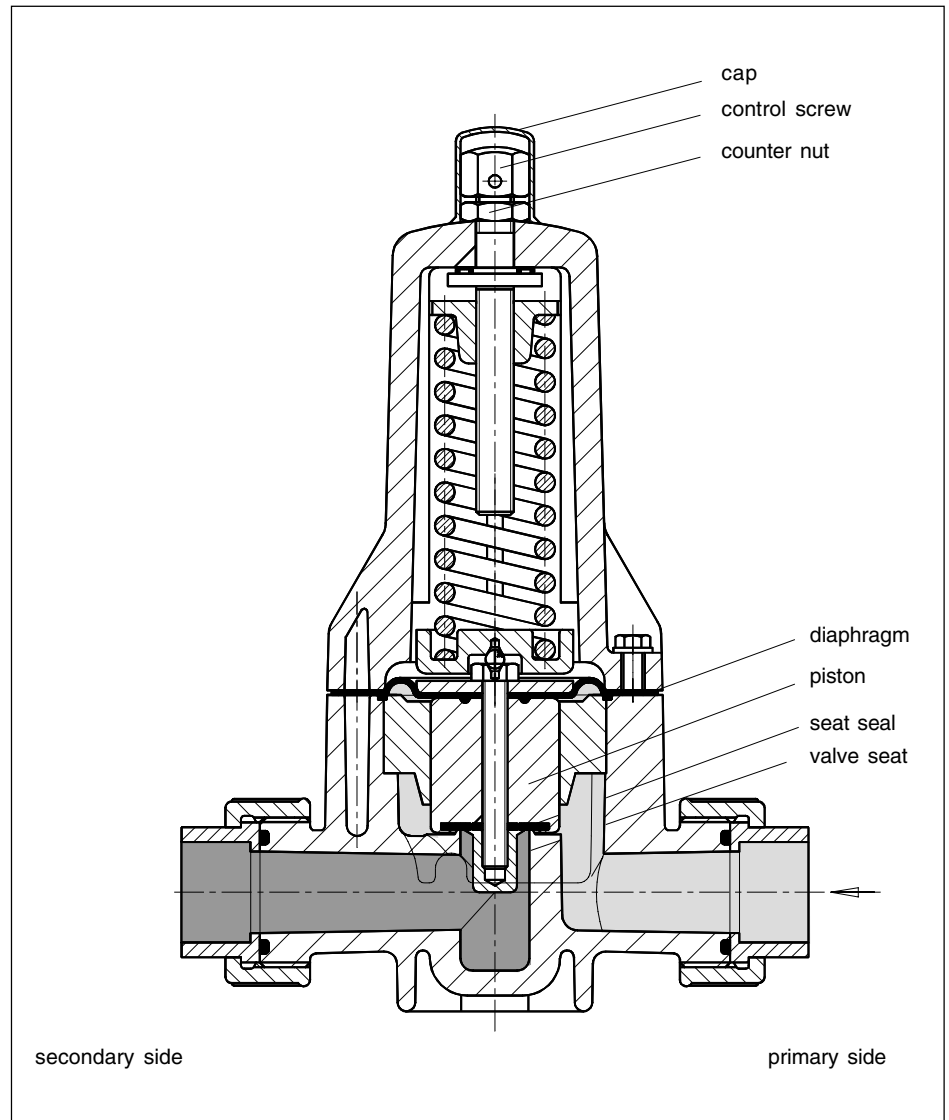

DIBt-approval

- PVC-U Z-40.23-193
- PP Z-40.23-194
- PVDF Z-40.23-195

DHV 715 with pressure gauge

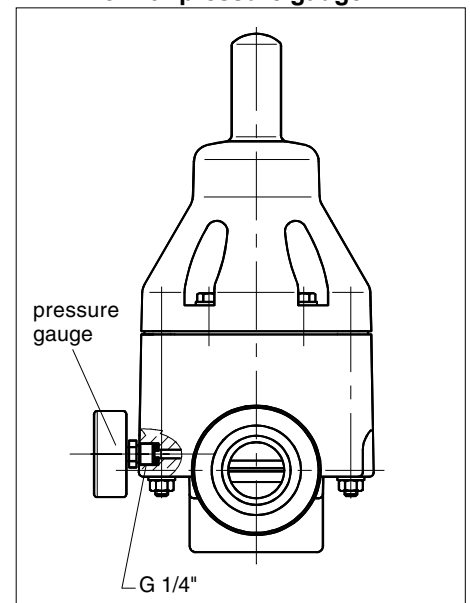

Material

Only thermoplastic material with high impact strength and high creep strength is used by ASV.

Valve body, piston, separation disc

- PVC-U (Polyvinyl chloride)
- PP (Polypropylene)
- PVDF (Polyvinylidene fluoride)

Valve bonnet

PP glass-fiber reinforced

Moulded diaphragm

EPDM, PTFE-coated on fluid side

Valve seat seal

- EPDM
- FPM

O-Rings at union ends

- EPDM
- FPM

Connecting screws

Stainless steel 1.4301 (AISI 304 / BS 304 S 15)

Technical data

Fluids

Technically clean, neutral or aggressive liquids provided that the selected materials are resistant at operating temperature.

Refer to the ASV resistance guide.

Installation

Variable, independent of flow direction.

Direction of flow

Direction of flow always in direction of arrow.

Pressure range

PN 10 at +20 °C

Operating pressure

See material pressure/temperature diagram.

Working pressure

Set pressure plus flow dependent pressure increase (see characteristic curves):

appr. 0.3 up to 10.0 bar

Opening pressure difference

DHV 715 approx. 0.2 bar

DHV 716 approx. 0.4 bar

DHV 725 approx. 0.2 bar

Hysteresis

Difference between opening and closing pressure: appr. 0.3 bar

Media temperature

Depends on the operating conditions (system pressure, load etc.). Taking creep strength into account, the following approximate temperatures apply:

- PVC-U: + 50 °C
- PP: + 70 °C
- PVDF: +100 °C

Colour

Body:

- PVC-U grey, RAL 7011
- PP grey, RAL 7032
- PVDF opaque (yellowish white)

Bonnet:

- PP-GFR orange, RAL 2005

Pressure/temperature diagram

The values are a guide for harmless fluids (DIN 2403) the material of the valve is resistant against.

The pressure/temperature limits are applicable for a computed operating life factor of 25 years at PN 10.

Durability of wear and tear parts is depending on the operating conditions of the application.

Values < 0 °C (PP < +10 °C) on request with exact data of operation.

Connection

1. Body with threaded necks acc. to DIN 8063 completed with:

- union nuts made of PVC-U, PP or PVDF
- union socket ends made of PVC-U, PP or PVDF
- O-ring sealings made of EPDM or FPM

On request we deliver:

- union spigot ends for fusion welding made of PP or PE
- dimensions acc. BS, ANSI and JIS on request

2. Body with spigot ends for solvent or fusion welding acc. ISO/DIN on request.

Pressure-temperature diagram

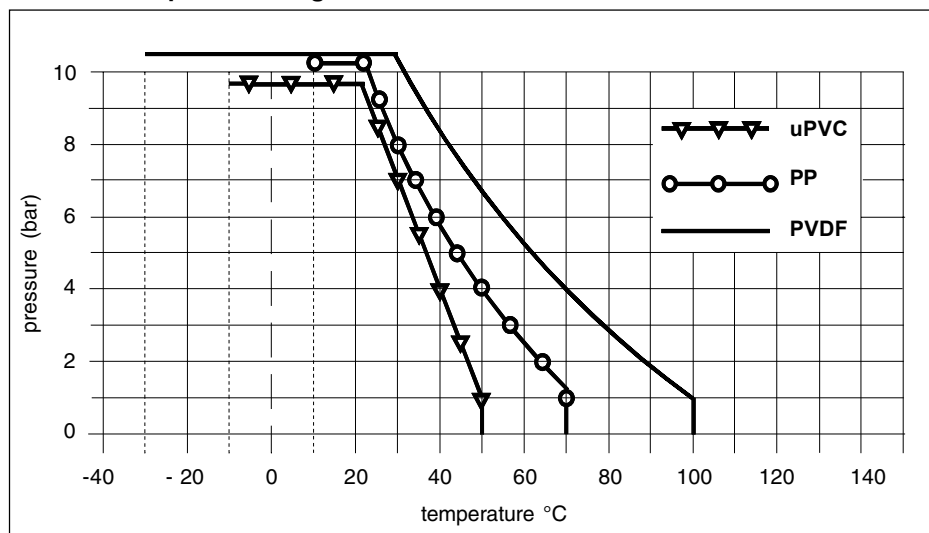

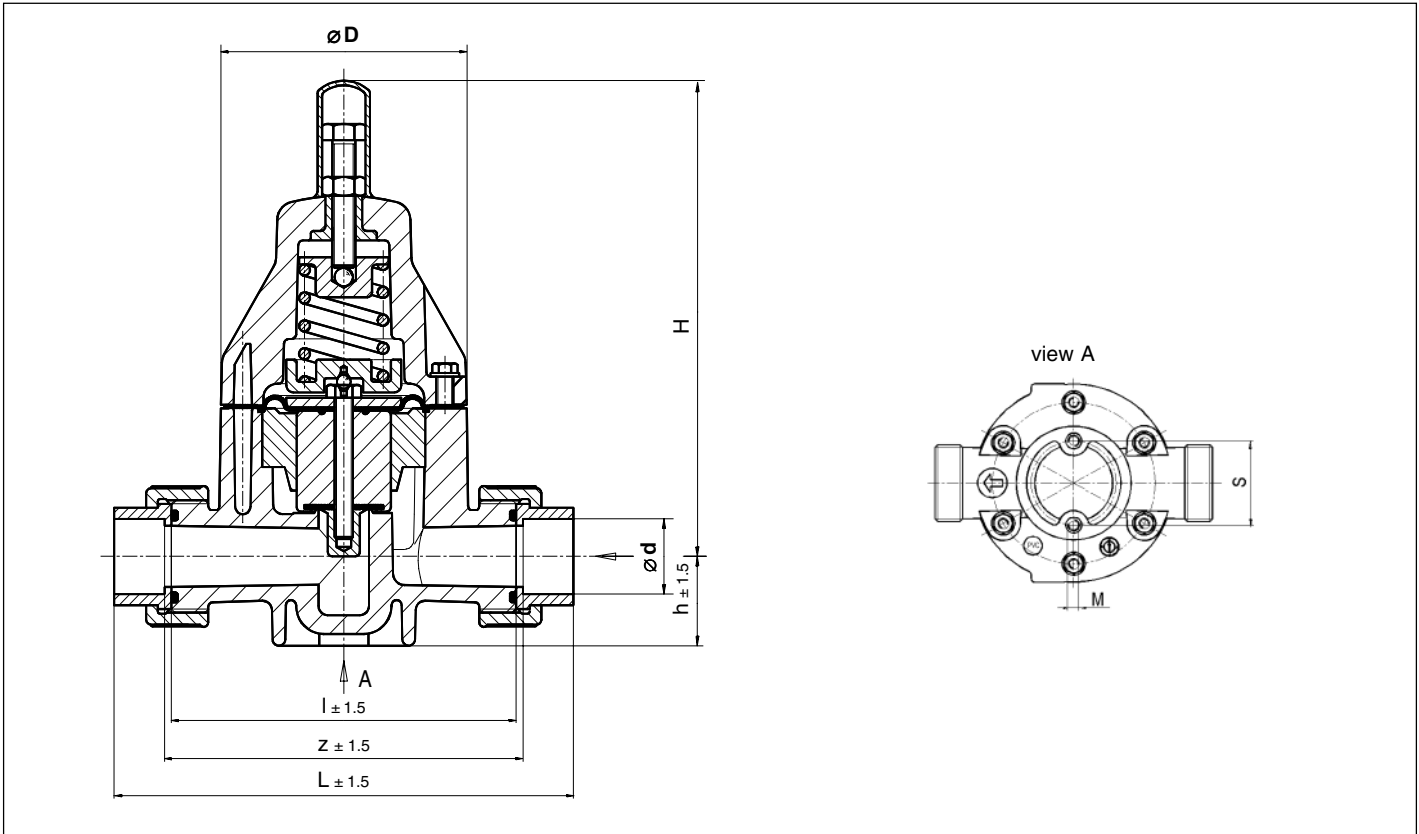
Dimensions DHV 715, DHV 716 and DHV 725 with union sockets

DHV 715 and DHV 716 with union sockets

Size			Dimensions mm													Weight kg (standard value)		
d	DN	DN	L			I		z		h		H	D	M	s	PVC-U	PP	PVDF
mm	mm	inch	PVC-U	PP	PVDF	PVC-U*	PVDF	PVC-U*	PVDF	PVC-U*	PVDF							
16	10	3/8	154	155	154	120	118	126	124	25	24	174	81	M 6	40	0.80	0.67	1.02
20	15	1/2	159	154	156	120	118	126	124	25	24	174	81	M 6	40	0.85	0.72	1.07
25	20	3/4	195	188	189	150	147	156	153	37	36	202	107	M 6	46	1.86	1.57	2.11
32	25	1	201	192	193	150	147	156	153	37	36	202	107	M 6	46	1.90	1.61	2.15
40	32	1 1/4	263	251	250	205	200	211	207	57	54	262	147	M 8	65	5.00	4.10	5.45
50	40	1 1/2	273	257	256	205	200	211	207	57	54	262	147	M 8	65	5.10	4.18	5.55
63	50	2	287	265	264	205	200	211	207	57	54	262	147	M 8	65	5.20	4.28	5.65

DHV 725 with union sockets

Size			Dimensions mm													Weight kg (standard value)		
d	DN	DN	L			I		z		h		H	D	M	s	PVC-U	PP	PVDF
mm	mm	inch	PVC-U	PP	PVDF	PVC-U*	PVDF	PVC-U*	PVDF	PVC-U*	PVDF							
16	10	3/8	154	155	154	120	118	126	124	25	24	207	81	M 6	40	0,98	0.82	1.20
20	15	1/2	159	154	156	120	118	126	124	25	24	207	81	M 6	40	1,00	0.84	1.24
25	20	3/4	195	188	189	150	147	156	153	37	36	243	107	M 6	46	2,20	1.90	2.45
32	25	1	201	192	193	150	147	156	153	37	36	243	107	M 6	46	2,25	1.95	2.52
40	32	1 1/4	263	251	250	205	200	211	207	57	54	348	147	M 8	65	6,00	5.20	6.45
50	40	1 1/2	273	257	256	205	200	211	207	57	54	348	147	M 8	65	6,21	5.41	6.66
63	50	2	287	265	264	205	200	211	207	57	54	348	147	M 8	65	6,40	5.60	6.87

* also valid for PP

Dimensions DHV 715, DHV 716 and DHV 725 with spigot ends

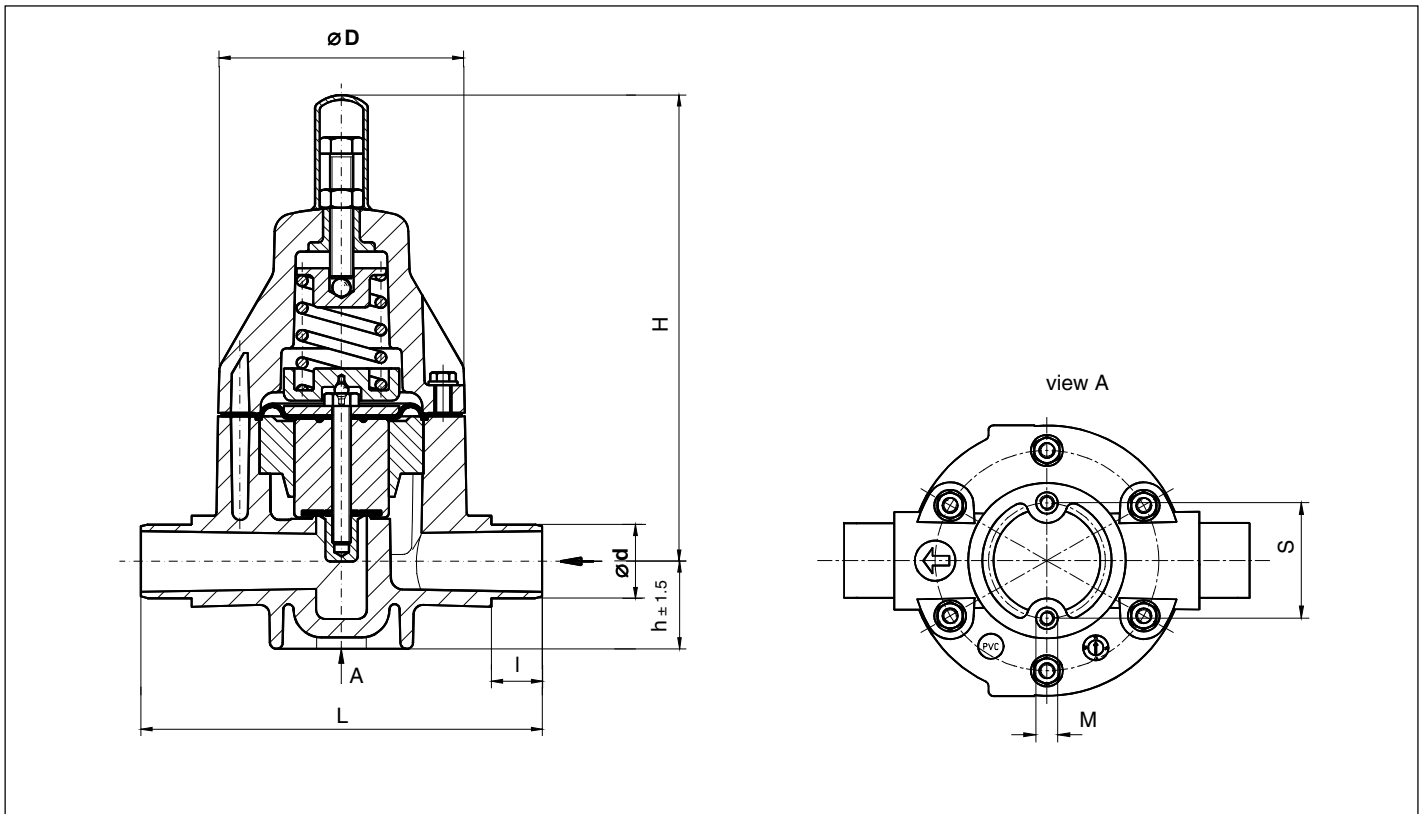

DHV 715 and DHV 716 with spigot ends

Size			Dimensions mm										Weight kg (standard value)		
d	DN	DN	L			l	h		H	D	M	s	PVC-U	PP	PVDF
mm	mm	inch	PVC-U	PP	PVDF		PVC-U*	PVDF					PVC-U	PP	PVDF
16	10	3/8	144 \pm 1.0	144 \pm 2.1	144 \pm 2.1	14	25	24	174	81	M 6	40	0.80	0.67	1.02
20	15	1/2	144 \pm 1.0	144 \pm 2.1	144 \pm 2.1	16	25	24	174	81	M 6	40	0.85	0.72	1.07
25	20	3/4	174 \pm 1.0	174 \pm 2.6	174 \pm 2.6	19	37	36	202	107	M 6	46	1.86	1.57	2.11
32	25	1	174 \pm 1.0	174 \pm 2.6	174 \pm 2.6	22	37	36	202	107	M 6	46	1.90	1.61	2.15
40	32	1 1/4	224 \pm 1.1	224 \pm 3.3	224 \pm 3.3	26	57	54	262	147	M 8	65	5.00	4.10	5.45
50	40	1 1/2	224 \pm 1.1	224 \pm 3.3	224 \pm 3.3	31	57	54	262	147	M 8	65	5.10	4.18	5.55
63	50	2	244 \pm 1.2	244 \pm 3.6	244 \pm 3.6	38	57	54	262	147	M 8	65	5.20	4.28	5.65

DHV 725 with spigot ends

Size			Dimensions mm										Weight kg (standard value)		
d	DN	DN	L			l	h		H	D	M	s	PVC-U	PP	PVDF
mm	mm	inch	PVC-U	PP	PVDF		PVC-U*	PVDF					PVC-U	PP	PVDF
16	10	3/8	144 \pm 1.0	144 \pm 2.1	144 \pm 2.1	14	25	24	207	81	M 6	40	0.80	0.67	1.02
20	15	1/2	144 \pm 1.0	144 \pm 2.1	144 \pm 2.1	16	25	24	207	81	M 6	40	0.85	0.72	1.07
25	20	3/4	174 \pm 1.0	174 \pm 2.6	174 \pm 2.6	19	37	36	243	107	M 6	46	1.86	1.57	2.11
32	25	1	174 \pm 1.0	174 \pm 2.6	174 \pm 2.6	22	37	36	243	107	M 6	46	1.90	1.61	2.15
40	32	1 1/4	224 \pm 1.1	224 \pm 3.3	224 \pm 3.3	26	57	54	348	147	M 8	65	5.00	4.10	5.45
50	40	1 1/2	224 \pm 1.1	224 \pm 3.3	224 \pm 3.3	31	57	54	348	147	M 8	65	5.10	4.18	5.55
63	50	2	244 \pm 1.2	244 \pm 3.6	244 \pm 3.6	38	57	54	348	147	M 8	65	5.20	4.28	5.65

* valid also for PP

Ident No. DHV 715 with union sockets

Body			PVC-U	PVC-U	PP	PP	PVDF	PVDF
Diaphragm			PTFE	PTFE	PTFE	PTFE	PTFE	PTFE
Sealing			EPDM	FPM	EPDM	FPM	EPDM	FPM
Setting range (bar)			0.2 - 4.0	0.2 - 4.0	0.2 - 4.0	0.2 - 4.0	0.2 - 4.0	0.2 - 4.0
d mm	DN mm	DN inch	Id.-No.	Id.-No.	Id.-No.	Id.-No.	Id.-No.	Id.-No.
16	10	3/8	119000	119007	119014	119021	119028	119035
20	15	1/2	119001	119008	119015	119022	119029	119036
25	20	3/4	119002	119009	119016	119023	119030	119037
32	25	1	119003	119010	119017	119024	119031	119038
40	32	1 1/4	119004	119011	119018	119025	119032	119039
50	40	1 1/2	119005	119012	119019	119026	119033	119040
63	50	2	119006	119013	119020	119027	119034	119041

Ident No. DHV 716 with union sockets

Body			PVC-U	PVC-U	PP	PP	PVDF	PVDF
Diaphragm			PTFE	PTFE	PTFE	PTFE	PTFE	PTFE
Sealing			EPDM	FPM	EPDM	FPM	EPDM	FPM
Setting range (bar)			0.5 - 10	0.5 - 10	0.5 - 10	0.5 - 10	0.5 - 10	0.5 - 10
d mm	DN mm	DN inch	Id.-No.	Id.-No.	Id.-No.	Id.-No.	Id.-No.	Id.-No.
16	10	3/8	119042	119049	119056	119063	119070	119077
20	15	1/2	119043	119050	119057	119064	119071	119078
25	20	3/4	119044	119051	119058	119065	119072	119079
32	25	1	119045	119052	119059	119066	119073	119080
40	32	1 1/4	119046	119053	119060	119067	119074	119081
50	40	1 1/2	119047	119054	119061	119068	119075	119082
63	50	2	119048	119055	119062	119069	119076	119083

Ident No. DHV 725 with union sockets

Body			PVC-U	PVC-U	PP	PP	PVDF	PVDF
Diaphragm			PTFE	PTFE	PTFE	PTFE	PTFE	PTFE
Sealing			EPDM	FPM	EPDM	FPM	EPDM	FPM
Setting range (bar)			0.2 - 10	0.2 - 10	0.2 - 10	0.2 - 10	0.2 - 10	0.2 - 10
d mm	DN mm	DN inch	Id.-No.	Id.-No.	Id.-No.	Id.-No.	Id.-No.	Id.-No.
16	10	3/8	119084	119091	119098	119105	119112	119119
20	15	1/2	119085	119092	119099	119106	119113	119120
25	20	3/4	119086	119093	119100	119107	119114	119121
32	25	1	119087	119094	119101	119108	119115	119122
40	32	1 1/4	119088	119095	119102	119109	119116	119123
50	40	1 1/2	119089	119096	119103	119110	119117	119124
63	50	2	119090	119097	119104	119111	119118	119125

Ident No. DHV 715 with spigot ends

Body			PVC-U	PVC-U	PP	PP	PVDF	PVDF
Diaphragm			PTFE	PTFE	PTFE	PTFE	PTFE	PTFE
Sealing			EPDM	FPM	EPDM	FPM	EPDM	FPM
Setting range (bar)			0.2 - 4.0	0.2 - 4.0	0.2 - 4.0	0.2 - 4.0	0.2 - 4.0	0.2 - 4.0
d mm	DN mm	DN inch	Id.-No.	Id.-No.	Id.-No.	Id.-No.	Id.-No.	Id.-No.
16	10	3/8	121922	121929	121936	121943	121950	121957
20	15	1/2	121923	121930	121937	121944	121951	121958
25	20	3/4	121924	121931	121938	121945	121952	121959
32	25	1	121925	121932	121939	121946	121953	121960
40	32	1 1/4	121926	121933	121940	121947	121954	121961
50	40	1 1/2	121927	121934	121941	121948	121955	121962
63	50	2	121928	121935	121942	121949	121956	121963

Ident No. DHV 716 with spigot ends

Body			PVC-U	PVC-U	PP	PP	PVDF	PVDF
Diaphragm			PTFE	PTFE	PTFE	PTFE	PTFE	PTFE
Sealing			EPDM	FPM	EPDM	FPM	EPDM	FPM
Setting range (bar)			0.5 - 10	0.5 - 10	0.5 - 10	0.5 - 10	0.5 - 10	0.5 - 10
d mm	DN mm	DN inch	Id.-No.	Id.-No.	Id.-No.	Id.-No.	Id.-No.	Id.-No.
16	10	3/8	121964	121971	121978	121985	121992	121999
20	15	1/2	121965	121972	121979	121986	121993	122000
25	20	3/4	121966	121973	121980	121987	121994	122001
32	25	1	121967	121974	121981	121988	121995	122002
40	32	1 1/4	121968	121975	121982	121989	121996	122003
50	40	1 1/2	121969	121976	121983	121990	121997	122004
63	50	2	121970	121977	121984	121991	121998	122005

Ident No. DHV 725 with spigot ends

Body			PVC-U	PVC-U	PP	PP	PVDF	PVDF
Diaphragm			PTFE	PTFE	PTFE	PTFE	PTFE	PTFE
Sealing			EPDM	FPM	EPDM	FPM	EPDM	FPM
Setting range (bar)			0.2 - 10	0.2 - 10	0.2 - 10	0.2 - 10	0.2 - 10	0.2 - 10
d mm	DN mm	DN inch	Id.-No.	Id.-No.	Id.-No.	Id.-No.	Id.-No.	Id.-No.
16	10	3/8	122006	122013	122020	122027	122034	122041
20	15	1/2	122007	122014	122021	122028	122035	122042
25	20	3/4	122008	122015	122022	122029	122036	122043
32	25	1	122009	122016	122023	122030	122037	122044
40	32	1 1/4	122010	122017	122024	122031	122038	122045
50	40	1 1/2	122011	122018	122025	122032	122039	122046
63	50	2	122012	122019	122026	122033	122040	122047

Spare part list

Item	Description	Quantity
DHV 715 / 716		
1	valve body	1
2	bonnet	1
3	separation disc	1
4	pressure disc	1
5	diaphragm*	1
6	pressure plate	1
7	spring plate	1
8	spring	1
9	steel ball	1
10	piston*	1
11	piston top*	1
12	flat disc*	1
13	hexagonal bolt*	1
14	steel ball/centering disc ¹⁾	1
15	hexagonal bolt	1
16	hexagonal nut	1
17	O-ring*	2
18	protection cap	1
19	hexagonal bolt	4
20	hexagonal bolt	2
21	hexagonal nut	6
22	U-washer	6
23	insert	2
24	union nut	2
25	protection cap	6
26	protection cap	6
27	U-washer	6
29	plug	1
DHV 725		
1	valve body	1
2	bonnet	1
2.1	spring nut	1
2.2	adjustment screw	1
2.3	hexagonal nut	1
2.4	cap nut	1
2.5	axial bearing disc	1
2.6	axial needle roller*	1
2.7	clamping sleeve	1
2.8	hexagonal nut	1
3	separation disc	1
4	pressure disc	1
5	diaphragm*	1
7	spring plate	1
8	spring	1
10	piston*	1
11	piston top*	1
12	flat disc*	1
13	hexagonal bolt*	1
14	steel ball/centering disc ¹⁾	1
17	O-ring*	2
18	protection cap	1
19	hexagonal bolt	4
20	hexagonal bolt	2
21	hexagonal nut	6
22	U-washer	6
23	insert	2
24	union nut	2
25	protection cap	6
26	protection cap	6
27	U-washer	6
29	protection plug	1

All parts marked with * are included in the respective wear and tear part set.
In case of spare part order please state complete valve ident No. and serial No.

¹⁾ from DN 32 with centering disc

Characteristic curves

The valve curves show the primary pressure or working pressure p_A in bar in relation to the flow Q in l/h.

The parameter is the set pressure p_E at $Q = 0$ l/h.

The curve shows the progression of the opening pressure.

The curves are valid for water at 20 °C.

Example: DHV 716, size DN 10

The valve is set closed at 5 bar.

At a pressure increase of 1 bar the flow of about 630 l/h is reached.

Working pressure p_A appr. 6.0 bar

Closing pressure p_S appr. 4.8 bar

Opening pressure p_O appr. 5.4 bar

Set pressure p_E appr. 5.0 bar

DN 10

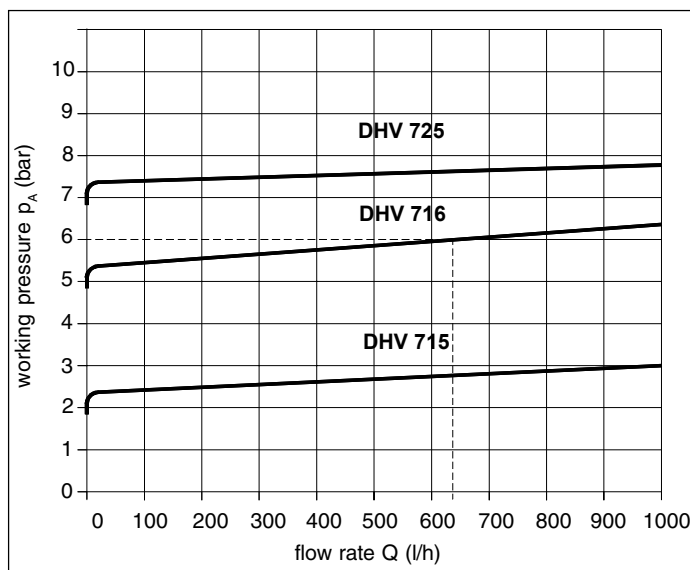

DN 15

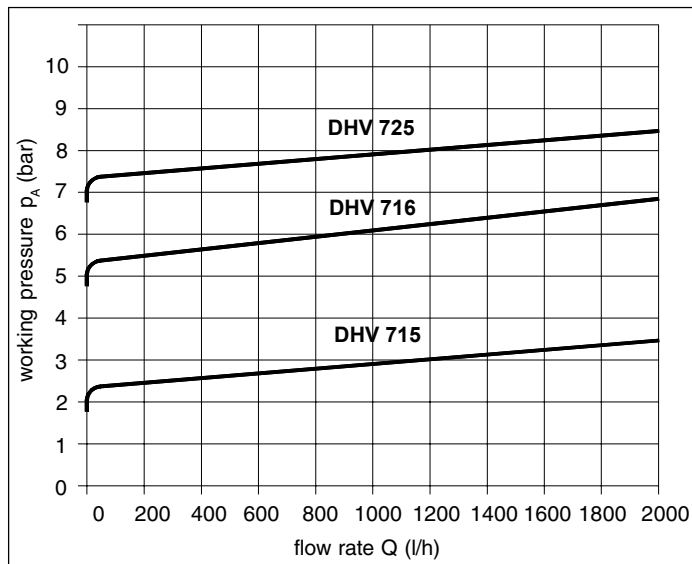

DN 20

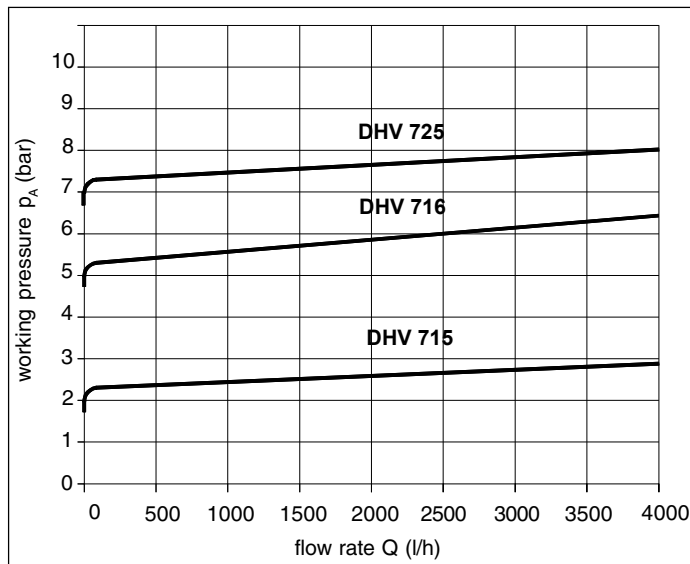

DN 25

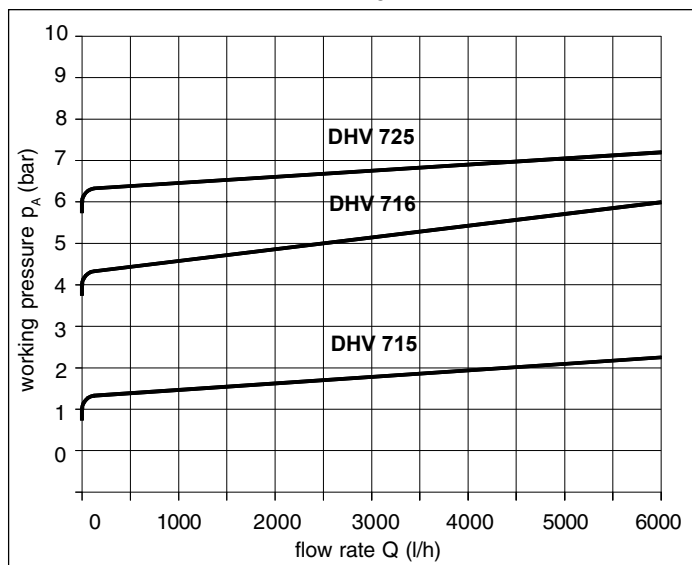

DN 32

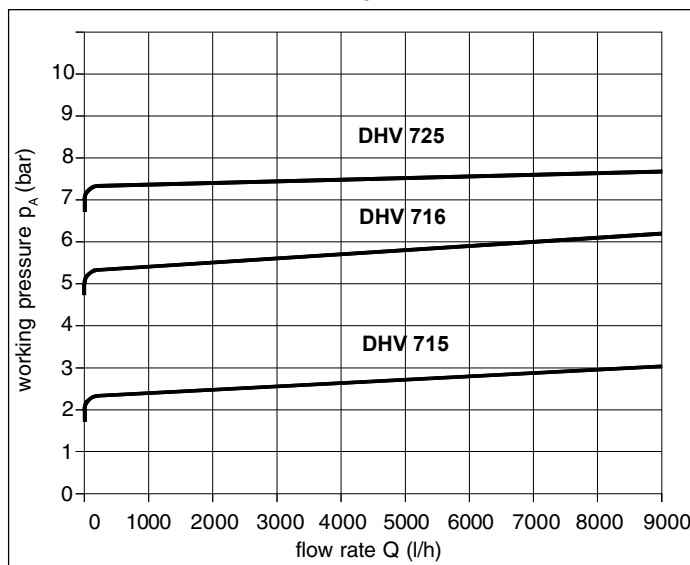

Characteristic curves

DN 40

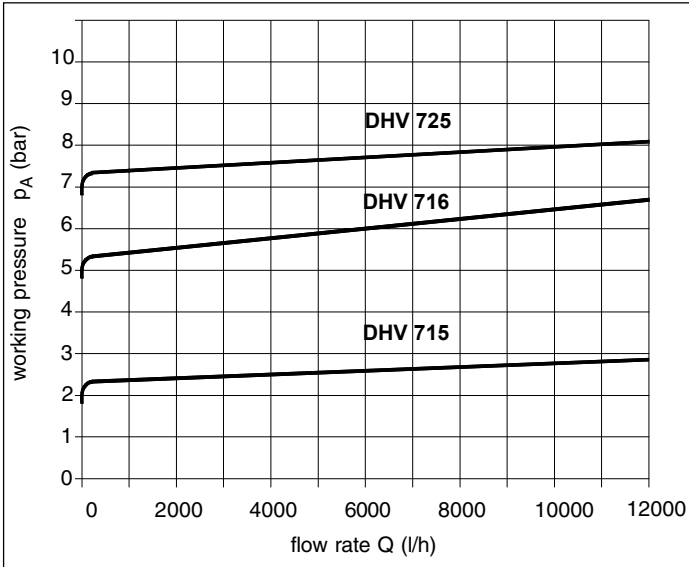

DN 50

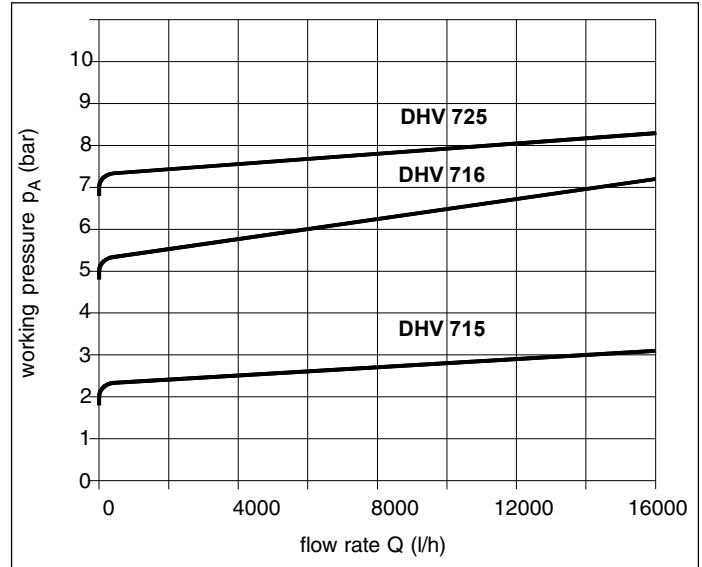

Pressure loss curves DHV 715 / 716 / 725

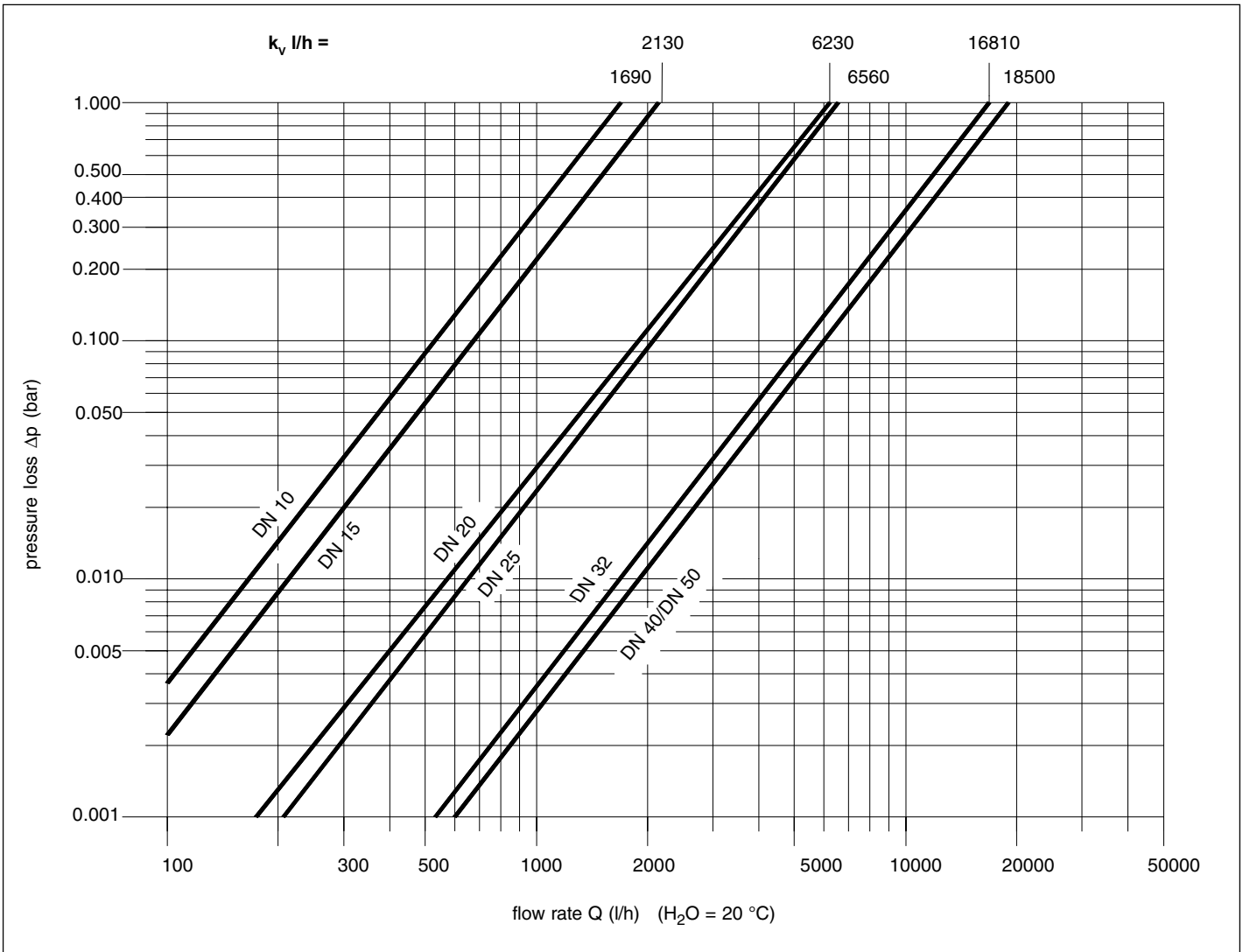

Application of pressure relief valve

1. Constant system pressure

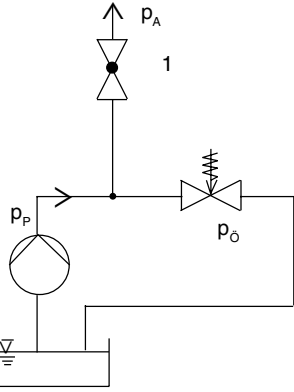

$p_p \geq p_A$
 $p_p \geq p_o \Rightarrow$ valve opens
 $p_p \leq p_o \Rightarrow$ valve closed

2. Consumer 1 and/or 2 open, valve closes

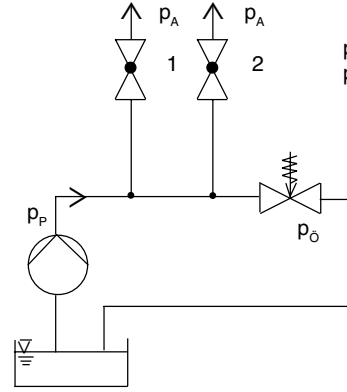

$p_p \geq p_o \Rightarrow$ valve opens
 $p_p \leq p_o \Rightarrow$ valve closed

3. DHV 715/716/725 as non-return valve. Container 1 is located above the pump.

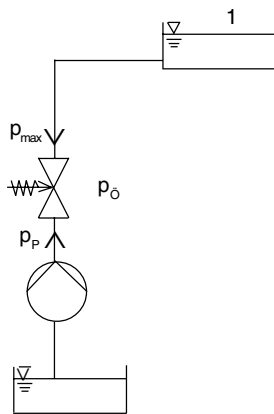

$p_o \geq p_{max}$
 $p_p \geq p_o \Rightarrow$ valve opens
 $p_p \leq p_o \Rightarrow$ valve closed

4. DHV 715/716/725 as overflow valve. Pressure of container or application system should not exceed the max. pressure value.

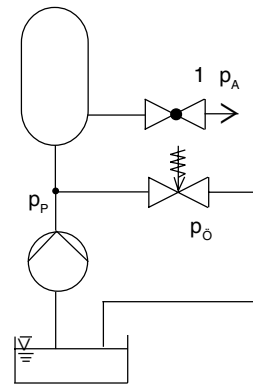

$p_o \leq p_A$
 $p_p \geq p_o \Rightarrow$ valve opens
 $p_p \leq p_o \Rightarrow$ valve closed

p_A = working pressure p_P = pressure of pump p_O = opening pressure

Failure, possible cause and repair

Failure	Possible cause	Repair
Valve leaking at diaphragm.	Diaphragm clamping pressure too low.	Fasten screws (19 and 20).
Pressure drops below set pressure.	Pistonguide or valve seat leaking. Diaphragm (5) leaking.	Piston or seat seal to be checked. Replace if necessary. Diaphragm to be replaced.
Pressure rises above set pressure.	Pistonguide is jammed or dirty.	Valve to be cleaned.
Valve is leaking at setting control screw.	Diaphragm damaged. Pressure plate clamping pressure too low.	Replace diaphragm. Fasten screw (13).



Operating instructions



Safe operation of the valve can only be ensured if it is properly installed, operated, serviced or repaired by qualified personnel according to its intended use while observing the accident prevention regulations, safety regulations, standards and technical regulations. The intended use includes adhering to the specified limit values for pressure and temperature as well as the chemical resistance referring to the operating conditions.

For this purpose, ensure that all components getting in contact with the media are "**resistant**" in accordance with the ASV resistance guide. The owner/user must inform the authorized qualified personnel instructed to perform the assembly, inspection and/or maintenance work of any potential danger emanating from the machine line/medium, and ensure that suitable safety measures are observed including local regulations and laws of the territories of use. Non-observance of the specified information and safety instructions may lead to injuries and/or property damages.

Installation

- Depending on the type of connection the pipe ends have to be properly prepared acc. to all technical standards.
- Valve to be radially installed acc. to all technical standards between the pipe ends. In case of flange connections the torques of the screws to fasten the flanges have to be observed.
- After proper installation the pipe system with all components has to be tested for leakages.

Disassembly

Note Adhere to the operating instructions.

- If required protection clothes must be worn.
- The pipe section is to be shut-off and to be emptied. Ensure a safe pressure release.
- Any fluid rest is to be disposed properly.

1. Valve bonnet

- 1.1. Position the valve upright.
- 1.2. Remove cap (18).
- 1.3. Loosen hexagonal nut (16/2.3) and hexagonal bolt/adjustment screw (15/2.2) so far until the spring (8) is totally released.
- 1.4. Remove housing bolts (19, 20) from body (1) and bonnet (2).
- 1.5. Bonnet (2) to be pulled off upwards. Remove spring (8), spring plate (7) and steel ball/centering disc(14).

2. Valve body and diaphragm

- 2.1. Perform the disassembly as already described under point 1.
- 2.2. Pull off piston (10), pressure disc (4) with diaphragm (5), hexagonal bolt (13), flat disc (12) and piston top (11) out of the body (1).
- 2.3. Carefully fix the piston, turn off piston top (11). Loosen bolt (13), pressure disc (4) with diaphragm (5) and flat disc (12).

Assembly

In the reverse order to disassembly.

- Diaphragm, valve seat, O-ring sealings to be checked for damages, dimension deviations, shore hardness etc. Replace if necessary.
- Screw torque (lubricated screws):

DN 10/15	6 Nm
DN 20/25	9 Nm
DN 32/40/50	12 Nm

Note

Consider tightening torque for mounting of pressure gauge: max. 3 Nm

Note

Elastomeres, especially the EPDM sealing elements, should not be touched or cleaned with synthetic oils, mineral oils, fats or cleaning agents. Danger of swelling. Only appropriate fats should be used, e.g. silicone greases.

We recommend:

Installing of filter or strainer (see print 330 034) directly before the valve for avoiding impurities e.g. at valve seat.

Western Region

(08) 9412 6100

hydramet@hydramet.com.au

Central Region

(08) 8374 7800

hydrasa@hydramet.com.au

Eastern Region

(03) 9325 3900

hydravic@hydramet.com.au

Technical alterations excepted