



The Simple, Economical Gas Transmitter for Monitoring Hazardous Gases in Ambient Air.

Series B12

2-Wire Gas Transmitter

SERIES B12

Series B12 transmitters are loop-powered instruments that transmit a 4–20 mA signal linearly proportional to gas concentration. Operated from a 24 VDC power supply, the transmitter will drive loads up to 675 ohms — sufficient for most monitoring applications. Alternatively, the unit can operate at 12 VDC — with reduced output load — for applications requiring battery operation.

Transmitters are normally supplied with the sensor close coupled to the enclosure. However, for special applications, the unit can be supplied with separate sensors that can be located up to 25 feet from the transmitter. Sensor duct mounting adapters and sensor flowcells can also be provided for specific applications. Contact ATI with details of any special requirements.

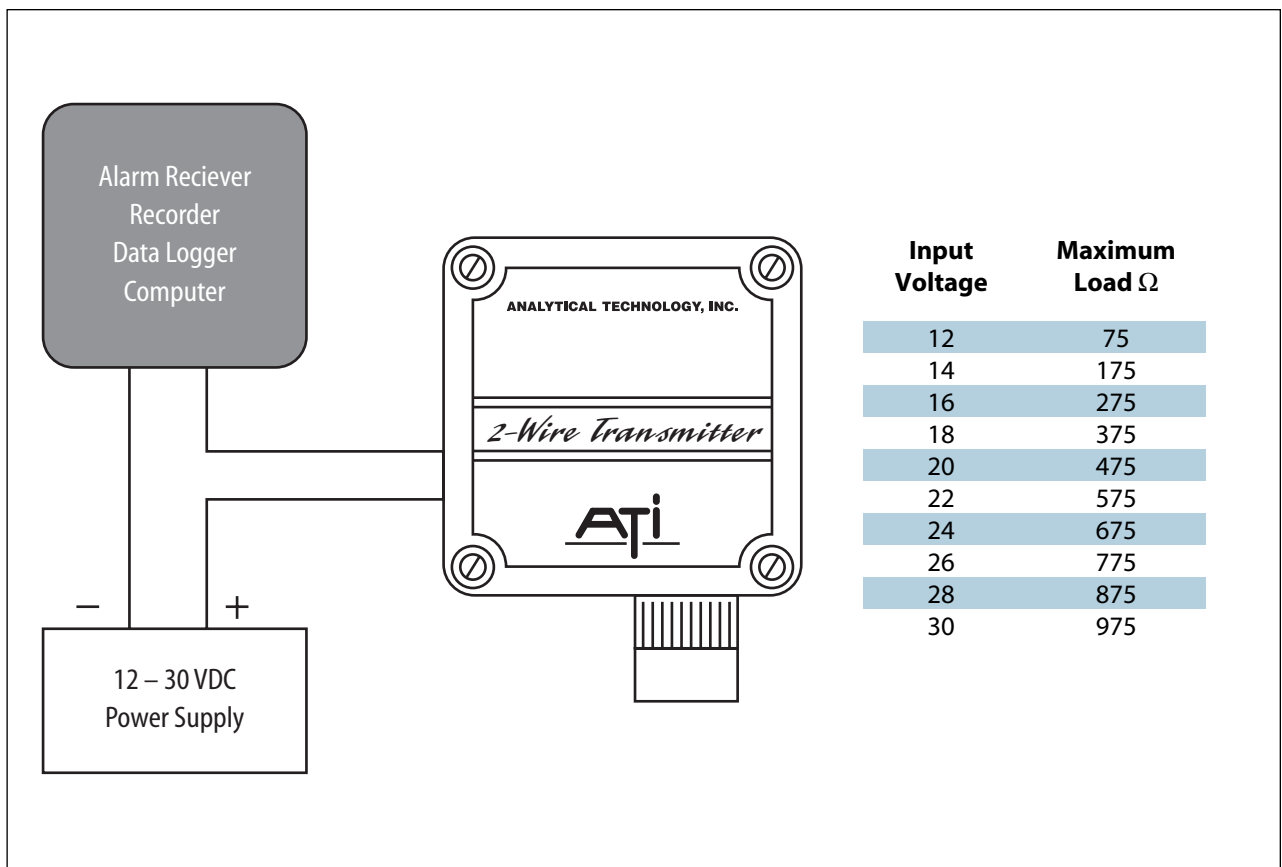

2-Wire Gas Transmitter



Specifications

Gas Type:	Customer-selected from available sensor list
Range:	Supplied with standard range for each gas unless otherwise specified
Accuracy:	Generally $\pm 5\%$ of value, but limited by available calibration gas accuracy
Electronic Repeatability:	$\pm 1\%$ of full scale
Electronic Linearity:	$\pm 0.5\%$ of full scale
Zero Drift:	Sensor dependent, but generally less than 2% of full scale per month, non-cumulative
Span Drift:	Application Dependent, but generally less than 3% per month.
Output:	Loop-powered 4–20 mA, 675 ohms maximum at 24 VDC
Power:	12–30 VDC
Enclosure:	NEMA 4X Polystyrene. Explosion-proof optional, Class 1, Div., 1, Groups B, C, & D
Controls:	Zero and span potentiometers mounted on transmitter circuit board
Operating Temperature:	-30° to +55°C (except oxygen, which is -10° to +55°C)
Sensor	
Pressure Limits:	7–30 PSIA (0.5–2 Bar)
Weight:	0.25 lbs (0.12 Kg.); 1.75 lbs (0.8 Kg.) for X-Proof unit
Display:	Optional 3-Digit LCD (not available with X-Proof enclosure)

Gas & Range Availability

Gas	Minimum Range	Maximum Range
Ammonia	0-100 PPM	0-2000 PPM
Carbon Monoxide	0-100 PPM	0-1000 PPM
Hydrogen	0-1000 PPM	0-10%
Nitric Oxide	0-50 PPM	0-500 PPM
Oxygen	0-5%	0-30%
Phosgene	0-1 PPM	0-100 PPM
Bromine	0-1 PPM	0-200 PPM
Chlorine	0-1 PPM	0-200 PPM
Chlorine Dioxide	0-1 PPM	0-200 PPM
Fluorine	0-1 PPM	0-200 PPM
Iodine	0-1 PPM	0-200 PPM
Ozone	0-1 PPM	0-200 PPM
Hydrogen Peroxide	0-10 PPM	0-2000 PPM
Hydrogen Chloride	0-10 PPM	0-200 PPM
Hydrogen Cyanide	0-10 PPM	0-200 PPM
Hydrogen Fluoride	0-10 PPM	0-200 PPM
Hydrogen Sulfide	0-10 PPM	0-500 PPM
Nitrogen Dioxide	0-10 PPM	0-200 PPM
Sulfur Dioxide	0-10 PPM	0-200 PPM
Arsine	0-1000 PPB	0-2000 PPM
Diborane	0-1000 PPB	0-2000 PPM
Germane	0-1000 PPB	0-2000 PPM
Hydrogen Selenide	0-1000 PPB	0-2000 PPM
Phosphine	0-1000 PPB	0-2000 PPM
Silane	0-10 PPM	0-2000 PPM
Acid Gases	0-10 PPM	0-200 PPM
Ethylene Oxide	0-20 PPM	0-200 PPM
Formaldehyde	0-20 PPM	0-200 PPM
Alcohol	0-500 PPM	0-2000 PPM
Acetylene	0-500 PPM	0-2000 PPM

How To Order

Specify model number using the suffixes below.

Model B12-CC-D-EEEE 2-Wire Gas Transmitter

Suffix CC

Gas Type – Standard range shown in parentheses

10 - Bromine (0-2 PPM)	21 - Hydrogen Chloride (0-20 PPM)	31 - Hydrogen Selenide (0-1000 PPB)
11 - Chlorine (0-10 PPM)	22 - Hydrogen Cyanide (0-20 PPM)	32 - Phosphine (0-1000 PPB)
12 - Chlorine Dioxide (0-2 PPM)	23 - Hydrogen Fluoride (0-20 PPM)	33 - Silane (0-10 PPM)
13 - Fluorine (0-2 PPM)	24 - Hydrogen Sulfide (0-50 PPM)	34 - Hydrogen Peroxide (0-10 PPM)
14 - Ozone (0-2 PPM)	25 - Nitric Oxide (0-100 PPM)	35 - Iodine (0-2 PPM)
15 - Ammonia (0-100 PPM)	25 - Nitrogen Dioxide (0-20 PPM)	36 - Acid Gases (0-10 PPM)
16 - Carbon Monoxide (0-100 PPM)	27 - Sulfur Dioxide (0-20 PPM)	37 - ETO (0-20 PPM)
18 - Hydrogen (0-4%)	28 - Arsine (0-1000 PPB)	38 - Formaldehyde (0-20 PPM)
19 - Oxygen (0-25%)	29 - Diborane (0-1000 PPB)	39 - Alcohol (0-1000 PPM)
20 - Phosgene (0-2 PPM)	30 - Germane (0-1000 PPB)	40 - Acetylene (0-1000 PPM)

Suffix D

Transmitter Enclosure Type

- 1 - NEMA 4X
- 2 - Explosion-proof
- 3 - Dual Condulet (explosion-proof systems only)
- 4 - NEMA 4X with integral LCD display
- 5 - NEMA 4X with Separated Sensor, 25-ft. sensor cable
- 6 - NEMA 4X with integral LCD display and Separated Sensor, 25-ft. sensor cable

Suffix EEEE

Measurement Range

Code the measurement range using a four digit number. The standard range for each gas is shown in parenthesis in Suffix CC. Minimum and maximum ranges are shown in the gas and range availability table on page 3. Consult the factory or your ATI representative for special ranges.

Suffix F

Units of Measurement

- 1 - PPM
- 2 - PPB
- 3 - %
- 4 - % LEL

Accessories

00-0118	Calibration adapter for standard sensors
00-0258	Calibration adapter for explosion-proof sensors
45-0046	Rain shield for explosion-proof sensors
00-0261	Remote calibration adapter
00-0255	Flowcell assembly for A10 standard sensor
00-0298	Flowcell assembly for C10 explosion-proof sensors

Represented By:



Western Region
(08) 9412 6100
hydramet@hydramet.com.au

Central Region
(08) 8374 7800
hydrasa@hydramet.com.au

Eastern Region
(03) 9325 3900
hydravic@hydramet.com.au

www.hydramet.com.au