



## Accurate Gas Measurement in Wet Gas Streams

Increasingly stringent air quality requirements have led to expanded use of wet scrubber systems to control air emissions. Chlorine storage facilities and chemical process plants are frequently required to scrub exhaust gas streams to remove halogen and acid gases.

Unfortunately, monitoring reactive gas concentrations in moisture saturated air streams presents problems for standard diffusion sensors. Condensing water in these air lines can quickly blind diffusion sensors, rendering them inoperable.

ATI's Series B12 Wet Gas System was developed to meet the need for reliable measurements in wet scrubber outlets for other gas streams that might be saturated with water vapor. Systems have been developed for monitoring strong oxidants (chlorine, bromine, chlorine dioxide, or ozone), acid gases (HCl or HF), and hydrogen.

The basic B12 Wet Gas System consists of a loop-powered 2-wire transmitter and a corrosion resistant

sensor specifically engineered to operate at 100% RH. Sensors are designed for direct insertion into vent stacks, or may be used in a flowcell if sample can be pumped to the sensor.

When remote display and alarm relay functions are required, the B12 Wet Gas Transmitters can be connected to ATI's B14 Alarm Receiver System. This system will provide direct digital display of gas concentration, plus 3 alarm setpoints, remote alarm reset input, and retransmitted 4-20 mA output. Or, the B12 transmitter may be used separately and tied directly to the users' DCS, PLC, or other equipment. Either way, the B12 is an excellent solution to a difficult monitoring problem.

### Take a look at these features:

- Direct measuring sensor
- Minimal maintenance
- Rapid response
- Stack mount or flow-through sensor
- Transmitter LCD display option
- Loop-powered electronics

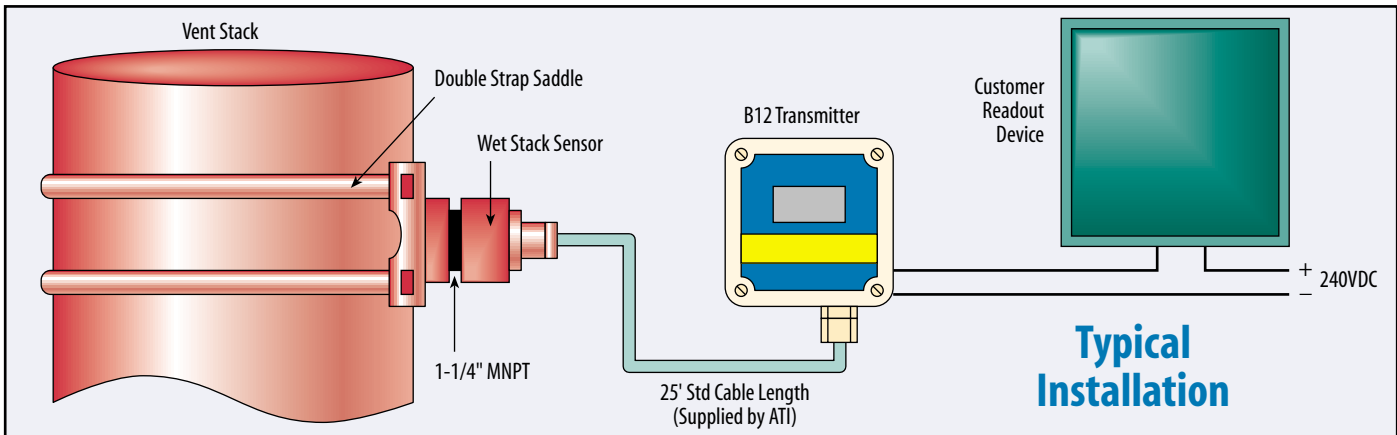

## Specifications

### Gas Type:

Oxidant gases: Cl<sub>2</sub>, Br<sub>2</sub>, ClO<sub>2</sub>, O<sub>3</sub>  
 Acid gases: HF, HCl  
 Hydrogen

### Range:

0-10, 0-20, 0-50, or 0-100 ppm for oxidant or acid gases. 0-2% or 0-10% for hydrogen.

### Accuracy:

Generally ±5% of value, but limited by available calibration gas accuracy.

### Electronic Repeatability:

±1% of span

### Electronic Linearity:

±0.5% of span

### Output:

Loop-powered 4-20 mA, 675 ohms maximum at 24 VDC

### Power:

12-28 VDC

### Enclosure:

NEMA 4X polystyrene, LCD display optional. Explosion-proof optional, Class 1, Div 1, Groups B, C, & D.

### Controls:

Zero and span potentiometers mounted on transmitter circuit board

### Operating temperature:

0° to +50°C

### Sensor materials:

Noryl

### Sensor cable:

25 feet standard, 100 feet maximum.

### Weight:

1 lb (0.4 kg)

## Ordering Information: Model B12-CC-D-EEEE-F

### Suffix CC - Gas Type

69 - Oxidant gas (specify Cl<sub>2</sub>, Br<sub>2</sub>, O<sub>3</sub>, or ClO<sub>2</sub>)  
 70 - Acid gas (specify HCl or HF)  
 71 - Hydrogen

### Suffix D - Transmitter Type

2 - Explosion-proof  
 5 - Standard NEMA 4X noryl  
 6 - NEMA 4X with LCD display

### Suffix E - Measurement Range

Code the measurement range using a 4-digit number. See specifications above for available ranges. For example, a standard wet chlorine transmitter with a range of 0-10 ppm would be coded 0010. A hydrogen system with a range of 0-2% would be coded 0002. Consult factory for availability of special ranges.

### Suffix F - Units of Measurement

1 - PPM  
 3 - %

### Accessories

00-0633 - Flowcell assembly/calibration adapter  
 Receiver - Series B14 alarm system (see separate B14 data sheet)



**Western Region**  
 (08) 9412 6100  
 hydramet@hydramet.com.au

**Central Region**  
 (08) 8374 7800  
 hydrasa@hydramet.com.au

**Eastern Region**  
 (03) 9325 3900  
 hydravic@hydramet.com.au

### Represented By:

