

Trace Contamination Detection

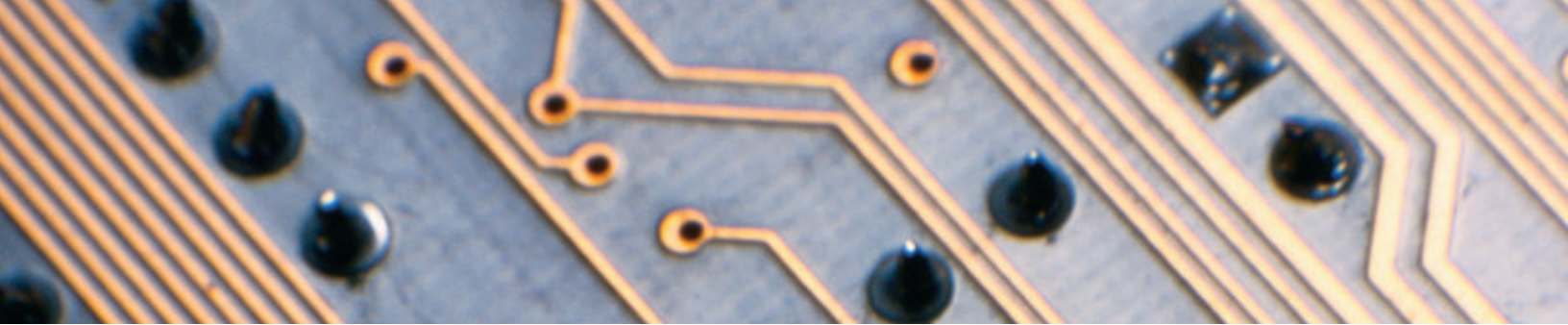

Model Q45C2

Conductivity/Resistivity Monitor



Low-level conductivity measurements are essential for monitoring a variety of high purity water systems. The proper operation of deionizers, reverse osmosis membranes, ion exchange systems, and heat exchangers require constant monitoring to ensure high quality production.

ATI's Model Q45C2 Conductivity Monitor provides the reliable and accurate low-level measurements required for such high purity water systems. Monitors provide large, easy-to-read LCD displays with a second display line for indication of temperature or other operational information. And for those applications where results in resistivity units are preferred, Q45C2 monitors can be programmed to display readings in Meg-ohm units instead of microSiemens.

Monitors are available in a variety of configurations, including a loop-powered transmitter, an AC-powered monitor with two user programmable alarm functions, and a

battery operated unit, either with or without an internal data logger.

The monitor employs 2-electrode conductivity sensors with low cell constants to provide continuous measurements from 0-20 to 0-2,000 microSiemens. The 2-electrode sensors are specifically designed for use in ultra-pure water and non-fouling applications. The sensors are available in several mounting configurations including 316SS compression fittings or sanitary-style. These sensors may also be mounted submersion-style or in a hot-tap configuration.

For almost any high purity conductivity application, the Q45C2 system will provide the reliability, ease of use, and flexibility you are looking for.

C tick compliant to AS/NZS C1SPR11:2004

File No: HYD100706A-2



N27131

System Features

Multiple Configurations: The Q45C2 monitor can be configured to measure and display Resistivity, Conductivity, or Total Dissolved Solids (TDS). The TDS factor is also user selectable.

Loop-powered, AC, or Battery Versions: Allows for easy implementation of loop-powered, line-powered, or battery-powered capability within the same instrument. The instrument can be rapidly converted between any of these versions with no requirement for software change.

- Loop-powered (16-35 VDC) Transmitter, 4-20 mA output
- Line-powered (115/230 VAC) Analyzer, dual relays, dual 4-20 mA outputs
- Battery-powered (9 VDC) Monitor, dual 0-2.5 VDC outputs

Large, Dual Line Display: The large, high contrast, super-twist display provides excellent readability over a wide

operating temperature range, even in low light conditions. The main display line consists of large, segmented characters with measurement units. The secondary display line utilizes easily readable dot matrix characters for clear display of calibration and diagnostic messages. Two of four measured parameters may be displayed simultaneously.

Intuitive User Interface: Four-button programming provides intuitive navigation through the menu driven user interface.

Dual Alarm Relays/Analog Outputs: AC operated systems provide two relays that are configurable for either "control mode" or "alarm mode" of operation. Outputs are assignable to either conductivity or temperature.

Flexible Calibration: Two-point and sample calibration options include stability monitors to check temperature and main parameter stability before accepting data.

Sensor Cell Constants

2-electrode conductivity sensors are classified by “cell constant” or “K”. The K value for a specific sensor relates to the electrode geometry. A sensor with a low K value is designed to provide high accuracy in low conductivity waters. However, the low K sensor is a poor choice for use in higher conductivity waters, as the response to changing conductivity becomes non-linear. A sensor with a higher K value, on the other hand, provides better accuracy in higher conductivity waters, but performs poorly in low conductivity waters. ATI’s Q45C2 system offers three sensors for use in the indicated conductivity ranges.

0.05 K: 0-2,000 or 0-20.00 μS ; 0-20.00 $\text{M}\Omega$ or 0-200.0 $\text{k}\Omega$

0.50 K: 0-20.00 or 0-200.0 μS

1.00 K: 0-2,000 μS

Sensor Mounting

The 2-electrode conductivity sensors are designed for direct installation into piping systems. It is important to install the sensors such that the electrodes are free of obstructions. For example, when suspended solids or air bubbles are present, improper installation can result in erroneous readings and increased maintenance.

The sensor should be installed horizontally with the electrodes directed into the on-coming flow of water. This prevents air bubbles and particulates from collecting in the space between the two electrodes. Any obstruction



2 Electrode Sensors

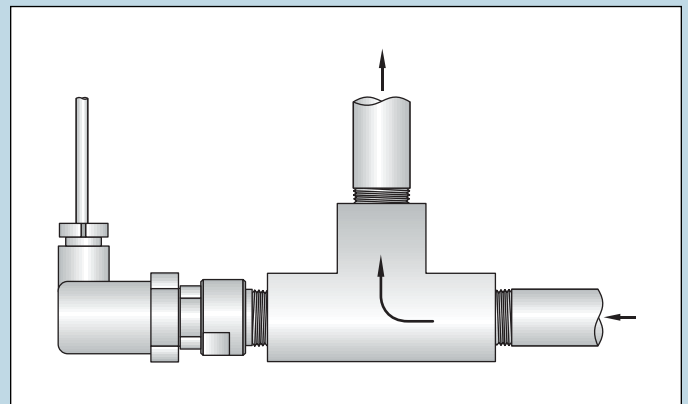

between the electrodes may cause the conductivity reading to either increase or decrease, depending on the nature of the obstruction.

Sensor Specifications

Measuring Range:	0.00 to 20.00, 0.0 to 200.0, or 0-2,000 μS , depending on cell constant	Temperature Range:	-10 to 125°C (14 to 257°F).
Wetted Materials:	PEEK®, titanium, Viton®, EDPM 316 Stainless Steel with Sanitary or Insertion body styles	Pressure Range:	0 to 100 psig
Temperature Compensation:	Pt1000 RTD or Pt100 RTD	Max. Flow Rate:	10 feet (3 meters) per second
Sensor Cable:	6 conductor plus 2 shields, HDPE jacket	Max. Sensor to Analyzer Distance:	60 feet (18.3 meters)
		Sensor Body Options:	1/2" compression fitting 3/4" inline fitting 1-1/2" or 2" sanitary-style
		Shipping Weight:	1 pound (0.45 kilogram)

Note: Refer to supplemental data sheets for individual sensor specifications

Ordering Information: Model Q45C2-A-B-C Conductivity/Resistivity Monitor

Suffix A - Power

- 1 - 24 VDC, 2-wire (single output only)
- 2 - 115 VAC with 2 relays
- 3 - 230 VAC with 2 relays
- 4 - Battery operated with two 0-2.5 VDC outputs
- 5 - Battery operated with internal data logger

Suffix B - Sensor Type

- 1 - 0.05 cell, titanium, 1/2"NPT compression fitting
- 2 - 1.00 cell, 316SS, 1/2"NPT compression fitting
- 3 - 1.00 cell, 316SS, 3/4"NPT in-line fitting
- 4 - 0.50 cell, 316SS, 3/4"NPT in-line fitting, high T/P
- 5 - 0.50 cell, 316SS, 1-1/2" sanitary fitting
- 6 - 0.05 cell, 316SS, 1-1/2" sanitary fitting
- 7 - 1.0 cell, 316SS, sanitary fitting
- 8 - 1.0K cell, SS, submersible, 3/4" PVDF mounting adapter

Suffix C - Sensor Cable Length

- 1 - 15 feet
- 2 - 30 feet
- 9 - Special

OPTIONS:

- 07-0100 NEMA 4X junction box
- 31-0057 Sensor interconnect cable
- 00-0628 Mounting bracket for submersible sensor.
- 09-0046 Conductivity standard, 84 μ S, 500 mL
- 09-0047 Conductivity standard, 447 μ S, 500 mL
- 09-0048 Conductivity standard, 1,500 μ S, 500 mL
- 09-0049 Conductivity standard, 8,974 μ S, 500 mL
- 09-0050 Conductivity standard, 80,000 μ S, 500 mL
- 47-0005 2" U-bolt, 304SS
- 05-0068 Panel mount bracket

Notes

1. All sensor cable lengths greater than 30 feet require a junction box (07-0100) and sensor interconnect cable (31-0057).
2. Pipe mount requires two 2" U-bolts (47-0005).
3. Panel mount requires bracket (05-0068).

Monitor Specifications

Enclosure:	NEMA 4X, IP66, polycarbonate, weatherproof and corrosion resistant, (HWD): 4.9" (124 mm) x 4.9" (124 mm) x 5.5" (140 mm)	Temperature Input:	Selectable Pt1000 or Pt100 RTD with automatic compensation
Mounting Options:	Wall, panel, pipe/handrail	Main Parameter Range:	0.00 to 20.00 MOhm 0.0 to 200.0 kOhm 0.000 to 2.000 μ S 0.00 to 20.00 μ S 0.0 to 200.0 μ S 0.0 to 2,000 μ S
Conduit Openings:	Three M16 openings, 3 cordgrips and 2 conduit adapters included	Accuracy:	0.1% of selected range
Weight:	Loop-powered transmitter: 1 lb. (0.45 kg); Other configurations: 2 lbs. (0.9 kg)	Repeatability:	0.1% of selected range
Ambient Temperature:		Sensitivity:	0.05% of selected range
Service:	-20 to 60°C (-4 to 140 °F)	Non-linearity:	0.1% of selected range
Storage:	-30 to 70°C (-22 to 158 °F)	Stability:	0.05% of span per 24 hours
Ambient Humidity:	0 to 95%, non-condensing	Temperature Drift:	Span or zero, 0.03% of span/°C
EMI/RFI Influence:	Designed to EN 61326-1	Warm-Up Time:	3 seconds to rated performance
Output Isolation:	600 V galvanic isolation	Max. Sensor to Analyzer Distance:	300 feet (91.4 meters)
Filter:	Adjustable, 0-9.9 minutes additional damping to 90% step input		



Represented By:



Western Region
(08) 9412 6100
hydramet@hydramet.com.au

Central Region
(08) 8374 7800
hydrasa@hydramet.com.au

Eastern Region
(03) 9325 3900
hydravic@hydramet.com.au

www.hydramet.com.au